

Specification

INPUT:	Audio	XLR-3, Hi Z balanced, 100K leg/leg 0dBV.7 nominal
	Looping CMRR	D25-M/D25-F (all Group), XLR3s Gp1 & 2 only. 40 dB minimum, nominal max >6v CM signal
	Switching	4 Balanced stereo pairs, electronic switching.
OUTPUT	PPM	Reduced 40 x 20mm scale dimension, to BS6840 Sifam manufactured, LED illumination
	Freq resp	-1dB nominal, @ 10Hz & >25KHz
	Ballistic	100mS (10KHz @ +8dB) peaks "6" 5mS (..) peaks "5"
	Peak Ind Phase	Red LED illuminated +8dB ± 0.15dB achievable Green/Red LED for correct/error respectively
	Presence Audio loudspeaker Headphone	Phase LED extinguished below approximately -25dB >2 Watts/channel (electrical power)200Hz - >16KHz Current limited OP on 1/4" Jack, mutes LSA
POWER	ac	100 - 250v ac 10 VA nominal
	fuse	3.15A T, delay
Case	Humidity	482W x 44H x 175D excluding connectors <3Kg non-condensing, Protection: IP50

Note: the figures in this specification are typical, and given for guidance only.

MURRAYPRO Mini-Mon3 Program Meter
conforms with the following EC Directive:-

89/336/EEC for EMC
73/23/EEC for LVD

EN550081-1 Part 1 Emissions,
EN550082-1 Part 1 Immunity,
EN60950 1992 Electrical Safety Sept 2008



LOOP via D25s

(GROUP 1)

(GROUP 2)

(GROUP 3)

(GROUP 4)

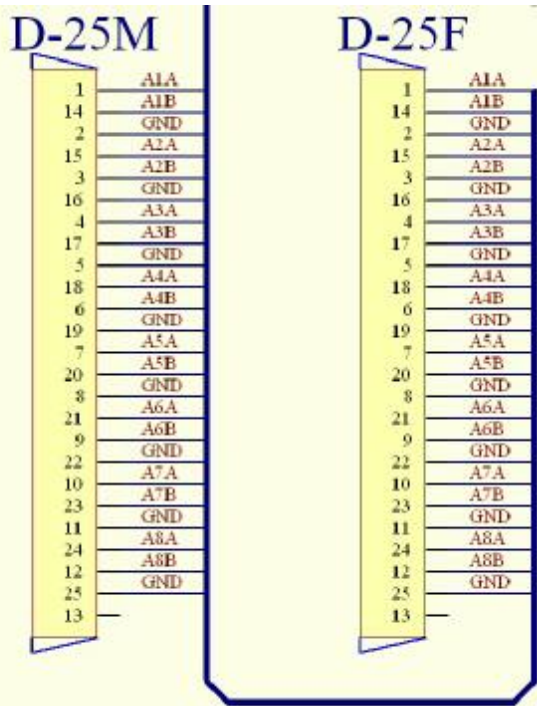

Murraypro

Mini-Mon3 MANUAL

(AES option **NOT FITTED**)

Designed and manufactured in the UK by Murraypro Electronics

Tel: (+44) 020 8943 1920

email: tech@murraypro.com

MiniMan3-2.lwp

Serial No:-.....

The MURRAYPRO MINI-MON3 provides high quality, full-function, stereo monitoring facilities in a compact unit only 1U high.

Designed for space limited, near-field audio monitoring applications, the self-contained MINI-MON provides stereo loudspeakers, current limited Headphone amplifier, Peak Programme Meters, Peak overload LEDs, stereo phase verification and audio presence confirmation, together with touch-latch selection between 4 analogue Stereo Groups.

True PPM scaling together with the classic fast attack and slow decay times are ensured by the high specification precision meter drive amplifier. The miniature movements that are fitted in this 1 U height unit have a slightly relaxed specification, but very closely emulate the full-sized BS 6840 meters. Internal, white LED illumination is provided to ensure full visibility of the meters under all operational conditions.

PEAK LEVEL INDICATOR

Independent ultra-bright red LEDs indicate peak input signal levels in excess of +8.15dBu (±0.15dB) for each channel. These LEDs conform with the full PPM specification, and are not subject to the ballistic considerations of meter movements.

For Loudness monitoring, to confirm conformance with ITU-R BS.1770-1, the Peak threshold may be reduced from +8.15 to +2.15dB, if desired.

PHASE VERIFICATION

Correct A1:A2 phasing is indicated by green illumination of the ϕ indicator. *Incorrect phasing* is immediately obvious as the **PPM** ϕ indicator *changes colour* to **red**. Relying on the basic algebraic functions of (L+R) & (L-R), the phase indication is extremely reliable, and is vital in an editing environment where the highly visual **GO~NO-GO** indicator provide this vital information instantly, preventing expensive mistakes which may only become apparent much later!

The phase indicator extinguishes when *both* A1 and A2 signals are below approximately -25dBu, preventing nuisance triggering on very low level signals.

AUDIO INPUTS & OUTPUTS

Audio inputs, as 4 Stereo Groups, are looped across complimentary D25s, and looping XLR-3 connectors (Gp 1 and 2only). Selection between groups is by front panel switch. **Gp 3&4** may be fed with analog audio from an **external DAC**. +2dB additional gain may be applied to Gp3 &4 via the front panel switch, normalising the -20dBFS SMPTE Reference Level to -18dBFS, for conventional PPM monitoring.

The selected source Group is fed via the volume control to a stereo balanced line driver, and is available on the rear panel XLR3-M to feed external amplifiers and loudspeakers. An internal link mutes the internal loudspeakers.

ADJUSTMENTS

There are **no** operational adjustments within the MINI-MON2. Gain of the PPM channels are set by the multiturn pots R37 & R38, **AFTER** checking that the meters accurately read “PPM 4” when the link LK1 is removed. R47 & R48 set the electrical calibration of the individual meter movements to compensate for

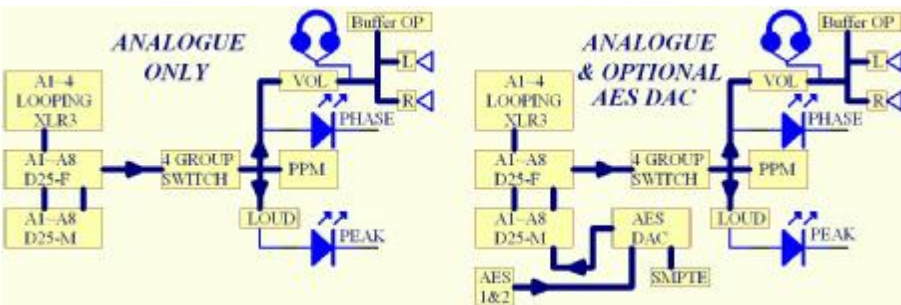

manufacturing tolerances in absolute sensitivity, they are **NOT** intended to adjust System Gain.. The trigger point of the peak LED indicators is set by “P2” to +8.15dBu (+0.15dB) on test.

DANGER OF ELECTRIC SHOCK & MAINS SAFETY

This “Class 1” equipment requires an electrical safety earth at all times, and is **not** specified for mains powered use under conditions of atmospheric precipitation, damp or condensing humidity. Fused at 3.15A T HRC. If a 13Amp plug top is used, Murraypro recommend that a 5A fuse is fitted. Under no circumstances should the fuse rating be increased.

Mains power to the Mini-Mon is normally provided by means of a fused, rear panel mounted, IEC input connector. The Mini-Mon is mounted within an earthed metal framed case, and is safe under operational conditions when fused as specified. However attention is drawn to the fact that **ELECTRICAL HAZARD** could exist if the case is opened by technically naive persons and the internal wiring is exposed to interference. Disturbance or modification to the mains wiring must be avoided or safety may be compromised.

Engineering adjustments, as described in an earlier passage, are not considered to be hazardous when undertaken by a competent person exercising due care. Murraypro always recommend that the mains lead is unplugged before the case is opened.

Murraypro Equipment is tested for electrical safety using a Seaward PAT1000s tester. Earth continuity is always checked and will not exceed 0.1 ohm at 8 Amps, including the resistance of the external mains cable used for testing.

Access to the case will require the removal of 3mm top cover screws. These screws must always be replaced, and tightened, before the Unit is returned to service. Removal of these screws signifies understanding and acceptance of this warning. Do not remove any of the cover screws if you have doubts concerning the above advice.

